

R. - Allradlenkung - All-wheel steering - Direction toutes roues - Dirección en todos los ejes - Besturing van alle wielen - Рулевое управление всеми поворотными колесами

Maße • Dimensions • Encombrement • Dimensiones • Afmetingen • Габариты крана

	A	A	B	C	D	E	F	G	H	I
		100*								
385/95 R 25 (14.00 R 25)	4000	3900	2750	2360	1508	1880	11,0°	9,0°	8,0°	12,0°

* abgeseñkt - lowered - abaissé - suspensión abajo - asvering afgelaten - шасси осажено

Stempelschotten	Stempelbasis	Draaicirkel ballast	Hoofdmast lengte	Jib lengte	Hijsblok gewicht
1,1m x 1,1m	6.7m x 7m	3.50 m	38.5m	(geen jib)	8.T = 250kg



Kraaninzet • Эксплуатация крана

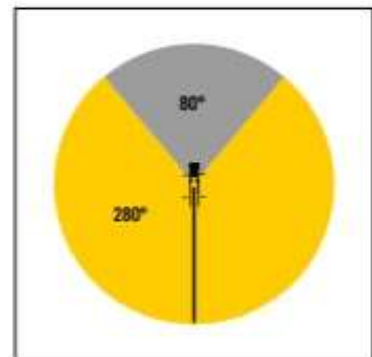
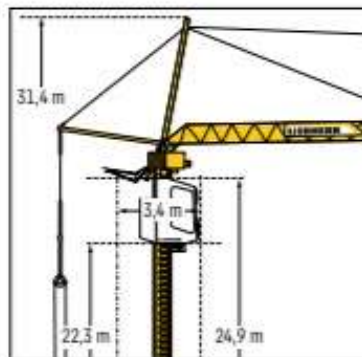
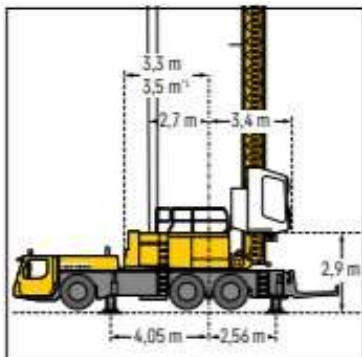
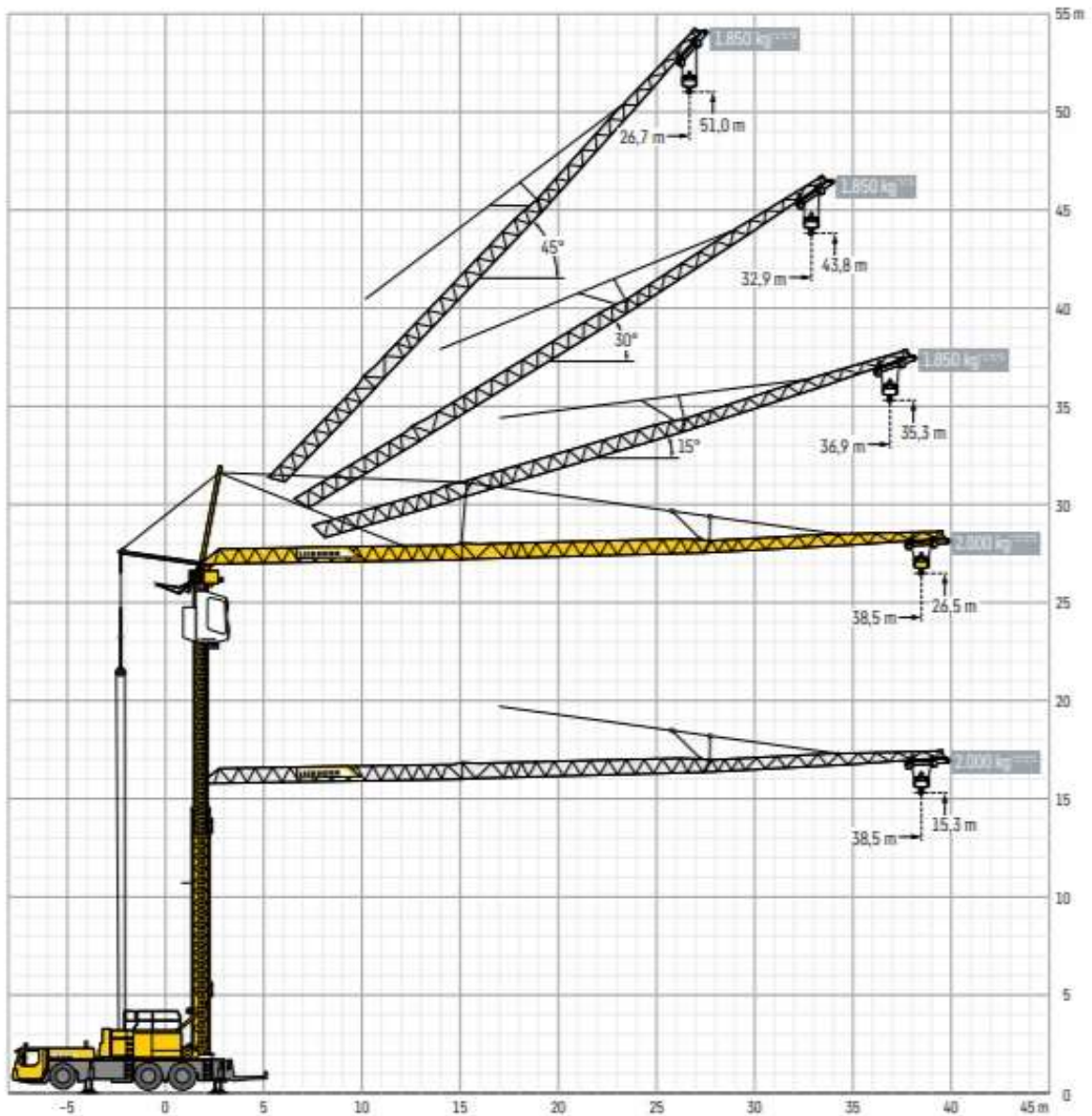



Mit Zusatzballast 1 + 2 · with additional ballast 1 + 2 · avec lest additionnel 1 + 2
con lastre adicional 1 + 2 · met extra ballast 1 + 2 · с дополнительным балластом 1 + 2



α°	m	α°	m	kg	m														
					12,0	14,0	16,0	18,0	20,0	22,0	24,0	26,0	28,0	30,0	32,0	34,0	36,0	38,0	38,5
0°	38,5	280°	3,2 - 12,5	6000	6000	5370	4710	4180	3750	3400	3100	2850	2630	2440	2280	2130	2000	1880	1850
		80°	3,2 - 12,0	6000	6000	5040	4330	3790	3360	3010	2720	2480	2270	2100	1940	1800	1680	1580	1550
	Plus ²	280°	3,2 - 13,5	6000	6000	5790	5070	4500	4040	3660	3350	3070	2840	2640	2460	2300	2160	2030	2000
		80°	3,2 - 13,0	6000	6000	5500	4700	4090	3610	3230	2920	2650	2430	2240	2070	1920	1790	1680	1650
15°	37,1	280°	3,2 - 37,1	1850	1850														
		80°	3,2 - 32,0	1850	1850												1720	1610	1550
	Plus	280°	3,2 - 26,0	2600	2600							2430	2280	2140	2020	1910	1850		
		80°	3,2 - 23,9	2600	2600					2590	2360	2170	2000	1850	1720	1610	1550		
30°	33,3	280°	3,0 - 11,0	6000	5500	4710	4100	3630	3250	2930	2670	2440	2250	2080	1940	1850			
		80°	3,0 - 11,0	6000	5470	4630	4010	3520	3140	2820	2560	2330	2140	1980	1830	1750			
45°	27,4	280°	2,7 - 27,4	1850	1850														
		80°	2,7 - 27,4	1850	1850														
	Plus	280°	2,7 - 20,0	2800	2800					2470	2210	1980	1850						
		80°	2,7 - 20,0	2800	2800					2470	2210	1980	1850						

kg